

Technical Information Sheet

Accoya® Siding - USA

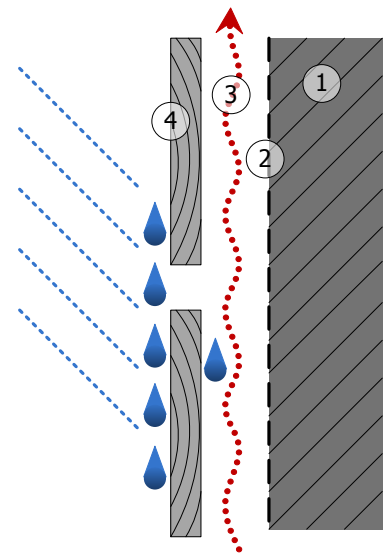

Ventilated cladding system



- 1 Structural wall
- 2 Breather membrane (house wrap)
- 3 Ventilated cavity
- 4 Accoya® siding boards

Do not:

- Mount panels in the splash zone – from ground level to a height of 8" to 10" – because of a reduction in coating service life
- Fit boards flush to masonry or brickwork

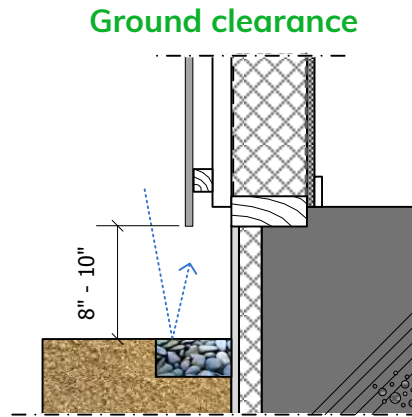

Important design considerations:

- Allow for sufficient ventilation in- and outlets at top/bottom (at least 0.03 in² per ft² cladding)
- The ventilated cavity should have a depth of at least 0.6"
- Design for furring strips, flashings and weeps to prevent water intrusion
- If necessary, use additional outdoor caulk or sealant around windows and doors
- The expansion due moisture and temperature changes is 1.5% (oven dry – wet)
- Trim: - extending down to a roof or deck requires a gap of at least 2" to avoid wicking - should be at least 6" above grade
- Consider increasing the speed of installing Accoya siding boards by milling a crusher bead into shiplap or tongue and groove profile

Joints

In practice, an expansion of 0.8% (65% RH – wet) needs to be considered. Install boards with a mutual distance of at least 0.04" and allow for 0.2" when meeting other construction elements and/or between the lengths of boards.

When joints are left open, use a UV resistant breather membrane and protect timber battens with a suitable weather resistant joint tape. Insert vermin mesh when applicable (joint width > 0.4")

Sub-frame

- Be aware of the risk of staining Accoya boards when using pressure treated or wood species prone to bleeding. In case of a risk of leaching, apply a barrier between the sub-frame battens and the Accoya siding boards
- Minimum dimensions 0.8" x 1.5" mm when battens are fully supported by a substrate; if not, use battens of at least 1.5" x 1.5"
- Use material of at least durability class 1 or 2
- Maximum sub-frame distance (on center):
 - 24" when applied over wood based sheathing
 - 16" if installed without sheathing
- Always install sub-frame vertically to ensure continuous ventilation
- In case of vertical boards, use vertical counter battens

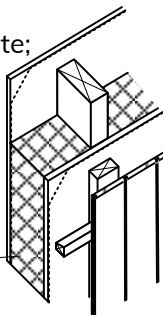

Siding

Round edges with a 0.12" radius when a film forming is applied
Install the boards heart facing outward when left uncoated

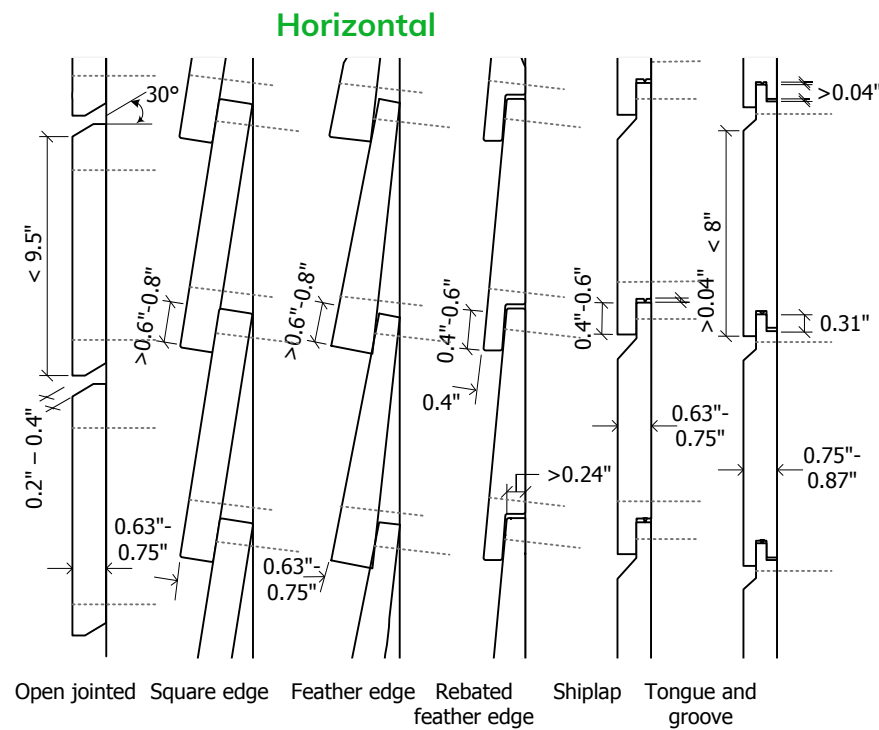

- •

Vertical & diagonal

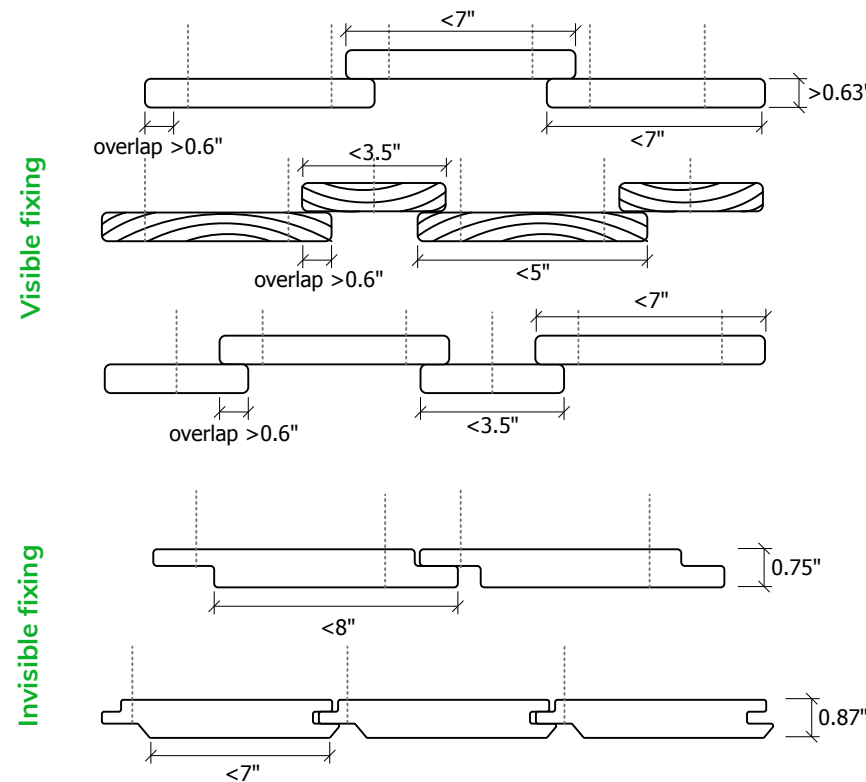

Visible fixing

Invisible fixing

! The system design must be in accordance with all applicable building regulations and standards. Please check your local building codes to verify the requirements in your area. **!**

Fasteners

- Use ring shank or other improved nails
- Stainless steel 304 or 316 strongly recommended
- Holes pre-drilled:
 - 0.04" less than nail Ø
 - to 80% of screw shank Ø

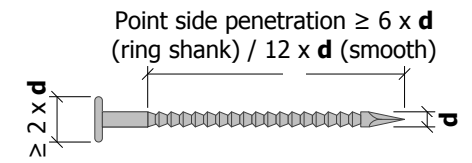

Do not:

- Use staples or T-nails
- Drive the nail/screw heads into the board
- Use galvanised or zinc plated fasteners or accessories
- Install siding in direct contact with concrete, stucco, masonry, top soil, mulch patios and/or roofs

Placing

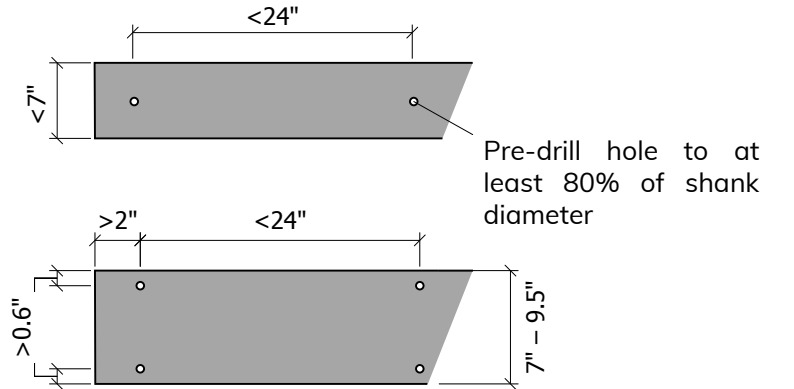

Best practice

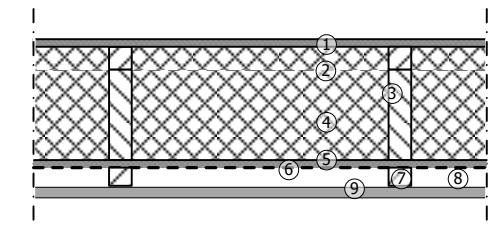

- | | |
|----------------------|---------------------|
| 1 Interior sheathing | 6 Breather membrane |
| 2 Vapor barrier | 7 Sub-frame |
| 3 Stud | 8 Ventilated cavity |
| 4 Thermal insulation | 9 Accoya® cladding |
| 5 Exterior sheathing | |

Handling & machining

Storage & handling

- Store boards horizontally, in reasonably dry (well ventilated) conditions and lifted clear of the floor
- Center bearers on 31" max and use at least 3 bearers
- Cover the boards with a breathable barrier / "vapour-open" plastic
- Storage at the building site:
 - should be at least 4" above concrete flooring and 1' above ground
 - additional protection from rain with plastic sheets is recommended
 - sufficient ventilation underneath the sheets is required to prevent mold

Transport

- In order to prevent damage, especially if coating is to be done on-site, products made of Accoya should be carefully transported
- Protection of joints is especially important

Cutting & machining

General

- Use conventional wood working equipment and tools - Accoya can be compared generally with harder softwood species
- Use carbide-tipped tools or diamond tipped for high(er) volumes
- Make sure that knives are aligned and sharp
- Spindle rotation velocity of 12,000 – 6,000 rpm
- Feed speed 550 – 1,100 yards per hour
- Use rubber out-feed rollers

Sawing

- Standard techniques such as using backer boards can be used when very fine results are desired

Planing & profiling

- Accoya shavings are fine and may be electrostatically loaded; in case of impression problems, increase the rpm or use anti-friction lubricants

Drilling

- Remove debris for deep drilling

Bending

- Use techniques similar to other softwoods
- **Do not** impregnate with ammonia to ease bending

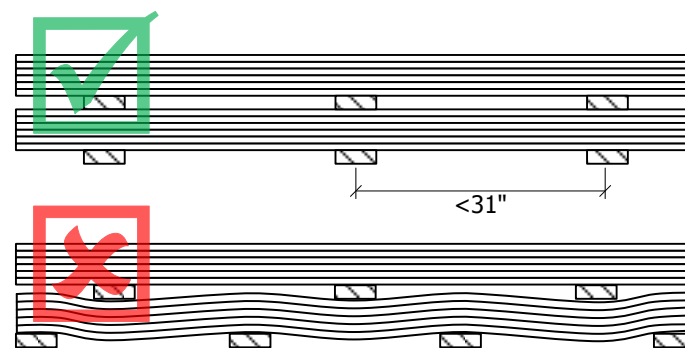

Coating

General

- There is no technical need to finish Accoya siding boards
- Uncoated Accoya is susceptible to outdoor weathering
- Mold growth can be avoided by using a suitable outdoor primer addressing mold growth

Preparation

- The Accoya should be dry - moisture content below 8%
- Surface must be clean, dry and free from dust and grease
- Finish the panels on all sides before mounting them
- Treat the edges of the boards with end-grain sealer
- For best results, any coating should best be applied industrially
- Round off corners with a radius of at least 0.12"

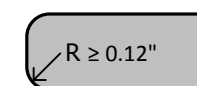

Changed properties

- Due to the hydrophobic nature of Accoya, water-based stains may not penetrate as deep or form as thickly
- The small amount of residual acetic acid may disturb the flow coating process, which can be prevented by adding an alkaline buffer

Best practices:

END SEAL

All exposed end grain should be coated with an effective end seal

ROUNDED CORNERS

All Accoya siding boards should be rounded with 0.12" radius corners

FACTORY COATING

Factory application of coatings is recommended to achieve optimum application

DARK TRANSLUCENT COLORS

Can provide longer maintenance intervals than lighter shades

FOUR SIDES COATED

Siding boards should be coated on all 4 sides for superior performance

LONGEVITY

Film forming coatings provide the longest maintenance intervals

OPAQUE COATINGS

A stain blocker is recommended

AVOIDING DISCOLORATION

Discoloration can be avoided by using a high quality UV resistant coating

Corner solutions

Interior corners

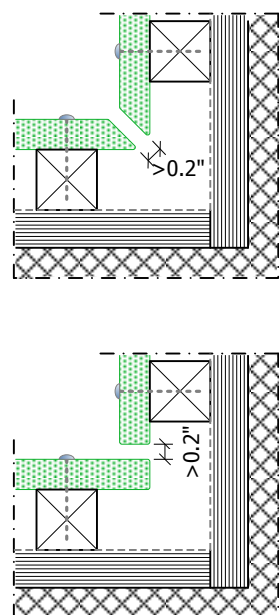

Exterior corners

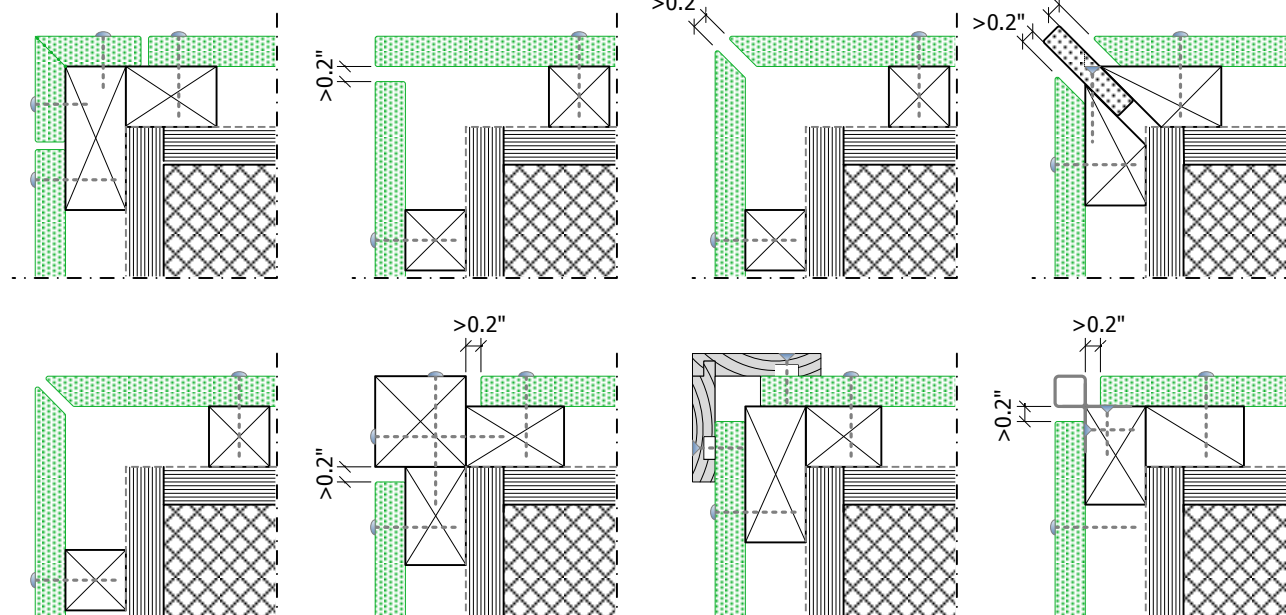

Depending on the applicable (National) building code, cavity barriers may be needed at corners

Fire retardants

If certain building codes call for it, Accoya can meet a higher fire performance than any standard wood product can achieve, by giving it a fire retardant treatment (FRT). This can be done by an impregnation with fire retardant chemicals or a treatment with a fire retardant (intumescent) primer over which a normal coating can be applied.

Alternatively, design measures can be taken to achieve a sufficient fire resistance of a wooden façade cladding. For more information, please contact our sales office at sales@accsysplc.com.

Wood Information Guide

For more and the most current information on wood properties of Accoya, please refer to the Accoya Wood Information Guide, that can be downloaded through the download section of our website www.accoya.com.

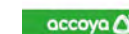

ACCOYA
Wood Information Guide V3.9

